

# Task 4.4: Service Improvements to Research Infrastructures for Detectors

Marko Mikuž

University of Ljubljana and Jožef Stefan Institute, Ljubljana, Slovenia



*This project has received funding from the European Union's Horizon Europe Research and Innovation programme under Grant Agreement No 101057511.*

# Task 4.4: Service Improvements to RIs in WP4

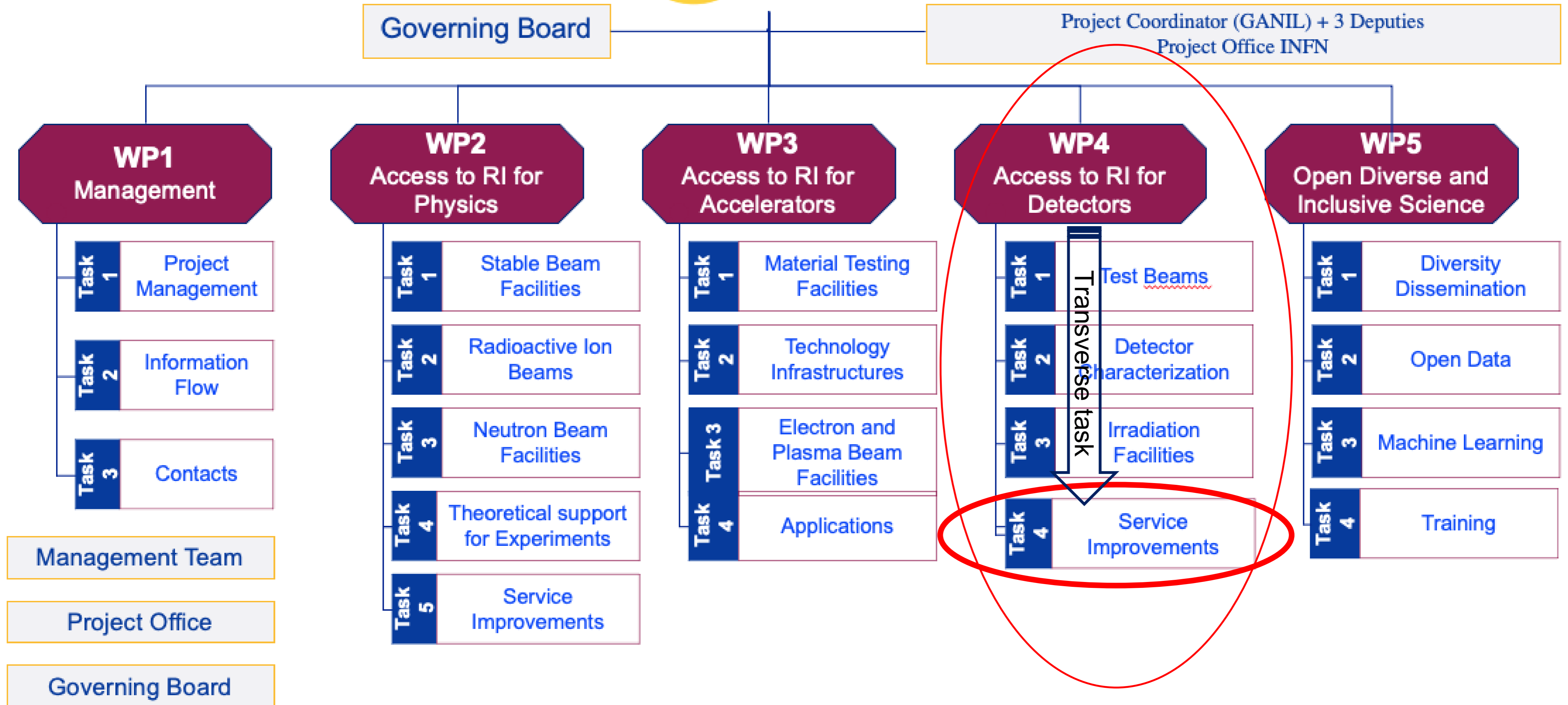

# Task 4.4: Service Improvements

- Aimed at improving access to WP4 RIs for EURO-LABS
  - Each RI proposed improvements with maximum impact on user access
  - Improvements were planned to be ready in **Y2** of the project
  - EC contributions matched by RI's own funding, typically exceeding EC



CERN TB, IRRAD & GIF++	Data base handling of beam time and irradiation requests
DESY Test Beams	Precision motion stages for large detector setups
PSI Test Beams	Beam monitor
RBI-AF	Ion beam focusing lens
ITAINNOVA	Cooling System and Graphical User Interface for EMC test station
CERN IRRAD	Beam profile monitor
JSI TRIGA	Cadmium shielding in the tangential channel
IFJ PAN AIC-144	2-D scanning table for irradiation
UCL CRC	Test chamber for the heavy ion irradiation facility
UoB MC40	Scanning system upgrade for high fluence delivery

# Task 4.4: Milestones

As improvements were planned to be ready in **Y2** of the project

➤ All milestones in P1 and P2

➤ All milestones delivered by M24

MS24	4.4.1	Development and test of the first prototype of the system	31 Aug 2023	JSI	Report on prototype functionality	
MS25	4.4.3	Prototype and software ready for lab tests	31 Oct 2023	JSI	Documentation on software and prototype	
MS26	4.4.4	Electrostatic Microprobe Quadrupole Quadruplet Lens Assembly installed and tested	31 Dec 2023	JSI	Installation report	
MS27	4.4.5	Cooling system developed	29 Feb 2024	JSI	Documentation on cooling system	
MS28	4.4.6	Upgrade BPM DAQ	31 Aug 2023	JSI	Demonstration of BPM DAQ	
MS29	4.4.6	ML-based classification and evaluation of the beam profile patterns	31 Aug 2024	JSI	Report on ML classification results	
MS30	4.4.7	Design of the shielding system including safety related aspects	31 Oct 2023	JSI	Design and safety documentation	
MS31	4.4.8	Design of the XY table and purchase of materials and equipment for the device	29 Feb 2024	JSI	Design documentation	
MS32	4.4.9	Design and commissioning of the beam line (vacuum and test chamber)	31 Aug 2023	JSI	Report on design and commissioning	
MS33	4.4.10	Mechanics of the setup adapted to fit into the experimental area	31 Aug 2024	JSI	Design documentation	

## • CERN: PS&SPS, IRRAD and GIF++ (WP4.1.1, 4.3.1 &

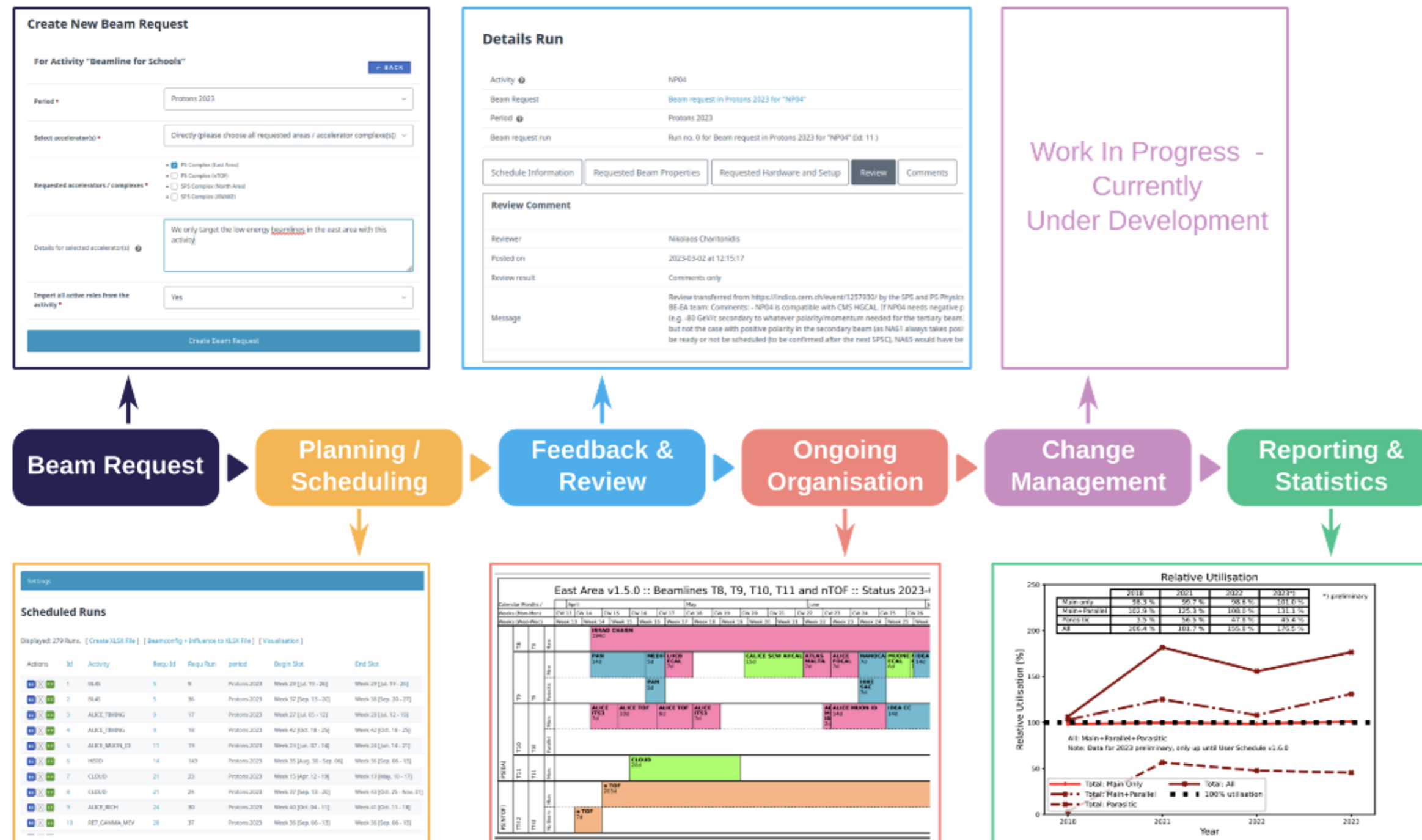

Work In Progress -  
Currently  
Under Development

### Objective:

Design, develop & deploy a data base driven tool to improve the handling of beam time requests and management of user schedules

### Significant activities and achievements:

- Implementation of first version completed, beam requests & user schedules for 2023 and PS & SPS testbeam users at CERN already handled using new tool
- Modular design; first module allowing reuse in existing software tools for Irradiation requests developed & tested
- Milestone report MS 2.4 submitted in time (August 31st 2023) => all objectives for first 12 months achieved ahead of time, ongoing developments reported.



### Next Steps, Ongoing Developments:

- Update data model using the lessons learned during 2023
- Preparation for PS & SPS beam requests 2024
- Explore potential for code sharing & reuse with other tools
- Work towards feature completeness

## 4.4.2 Longer-range motion stages

- Used for mounting DUTs in beam telescope setup
- DESY: WP4.1.2

.Need for larger range of motion for scans of large-scale DUTs (e.g. strip petals) in telescope setup expressed by several groups

.Our standard model is also available with 30 cm range (M-531)

One of the stages already replaced by M-531

The second stage arrived in October'23

- 13 months lead time !
- ✓ Installation and commissioning swift, no MS report
- ✓ SI finished well before M24

Since the SI installation in 2023 users experience

- shorter setup times
- more independence during setup
- more robust results

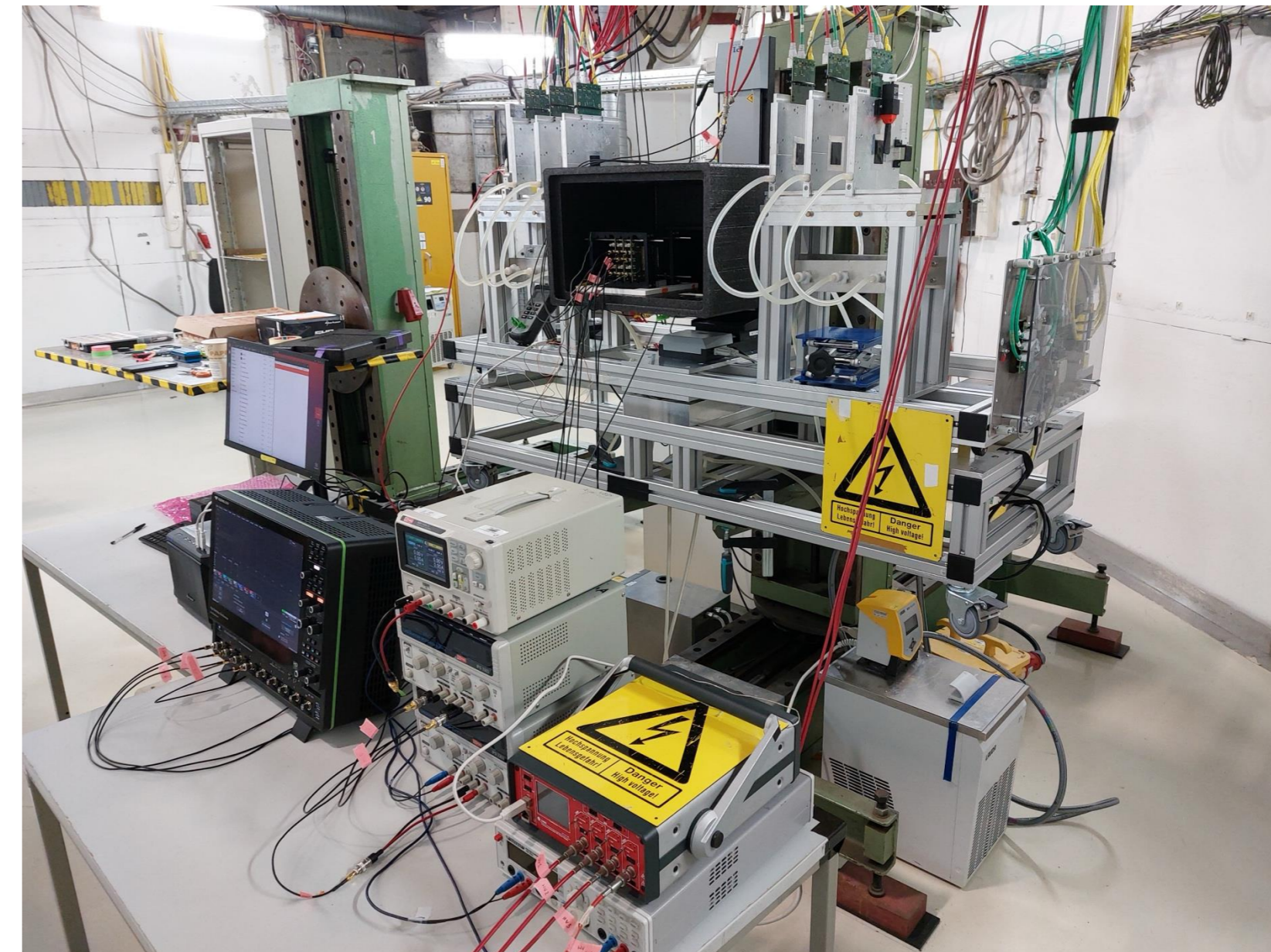
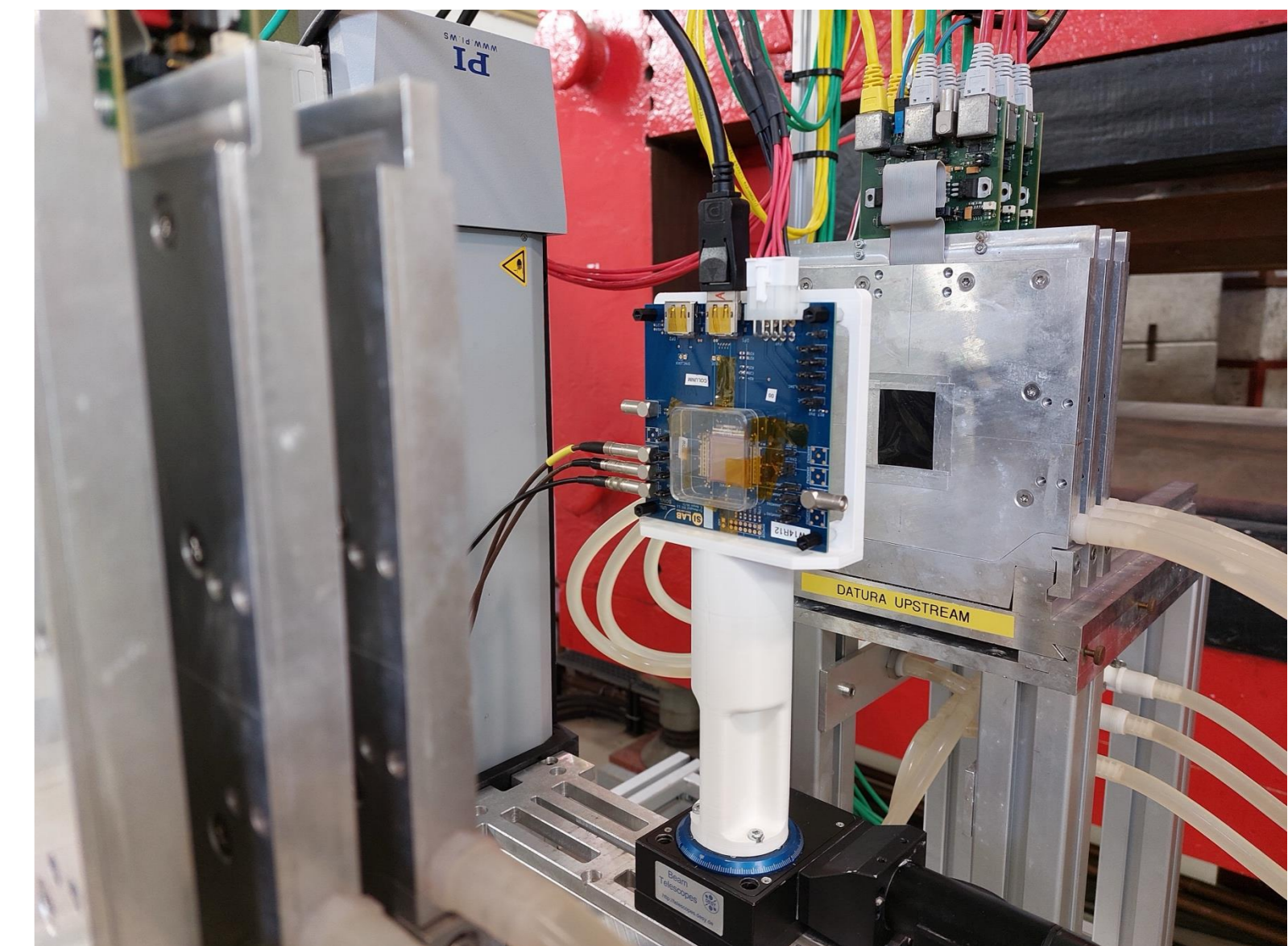

## 4.4.3: Scintillating Fiber Beam Profile Monitor



### PSI – PiM1 – ScFi-Beam Monitor

- Monitor for beam diagnostics
  - Profile
  - Rate
  - Composition
    - Low energy particles («surface muons»):  $dE/dx$
    - High (decay in flight): TOF
- 2 Layers of 21 fibres (X,Y) pitch 5mm, length 260mm
- Fibres: Saint Gobain Double cladding square 500µm
- Photosensors: Hamamatsu MPPC S13360-1350CS
- DAQ + TRG: Wavedream + “OR” of all “AND” from SiPM on the same fibre
- Status:
  - 1st prototype tested in air (PiM5, 28 MeV/c positive Muons)
  - 2nd prototype for operation in Vacuum in construction
  - Final system on movable stage in design process

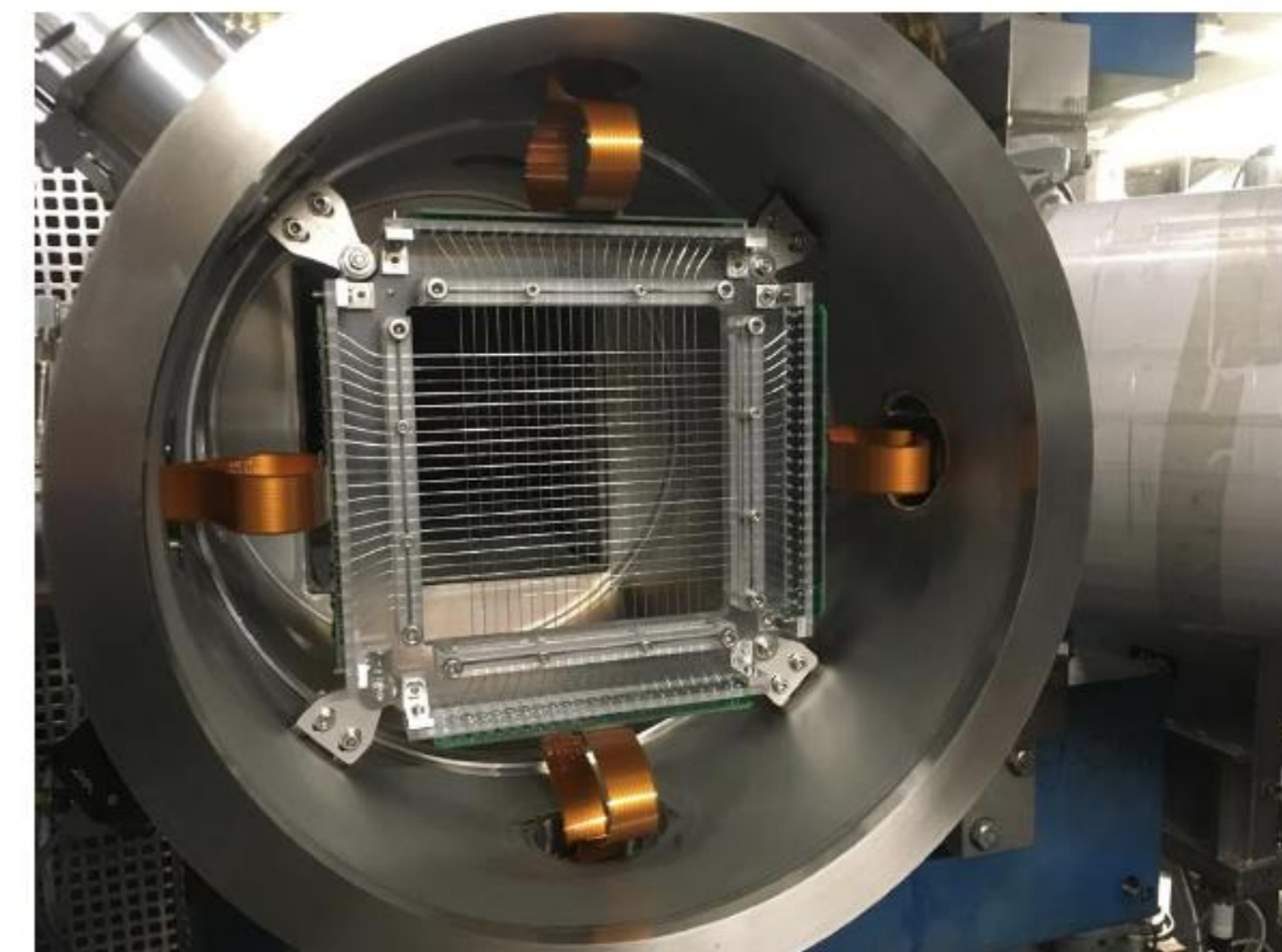
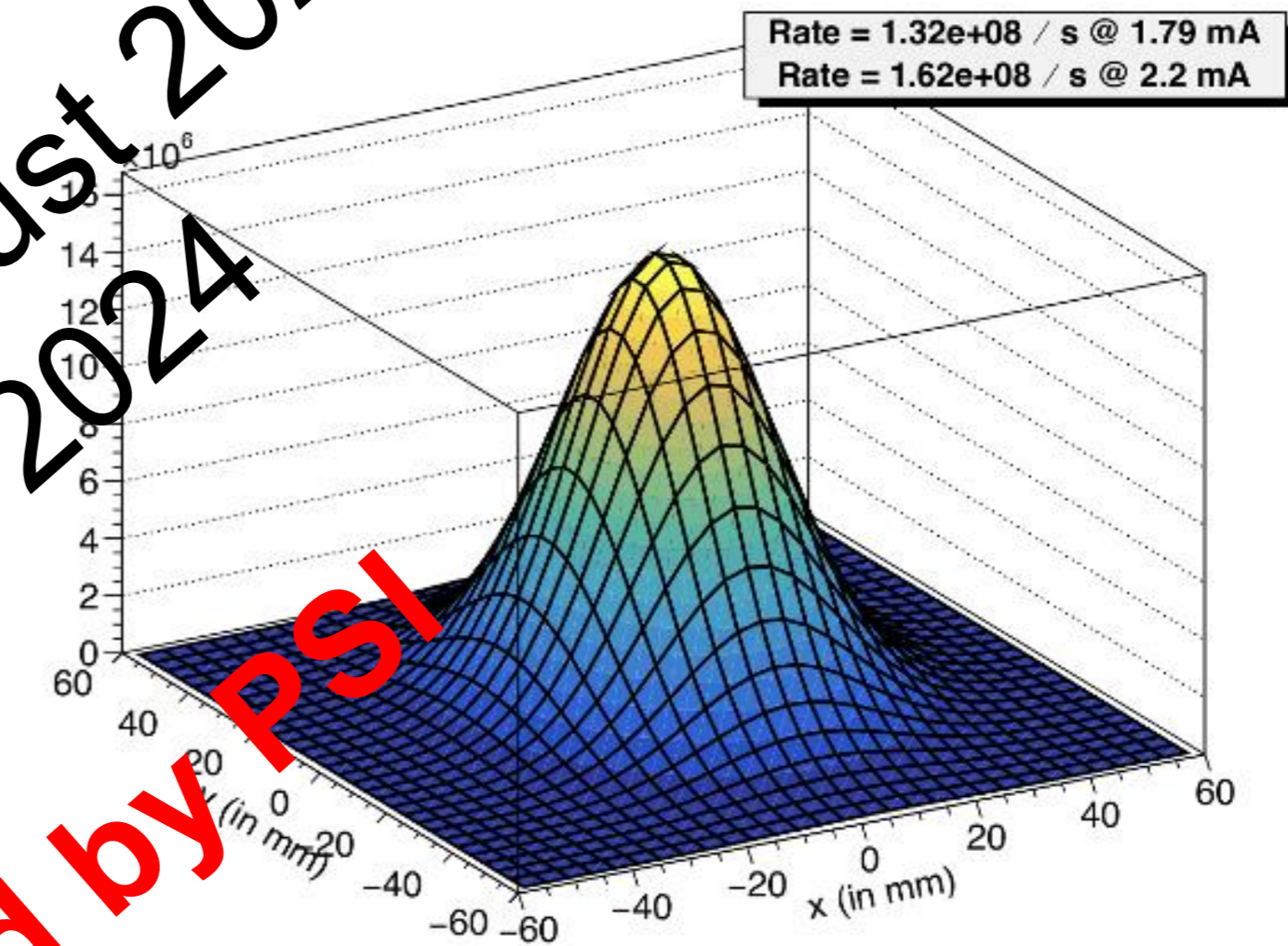

MS25 due end October!



Milestone MS25 passed in August 2023  
Aimed for installation in 2024  
Project cancelled by PSI

# 4.4.4: Improvements of the dual microbeam (DuMi)

• Detector testing at RBI: WP4.2.2

## RBI Tandem Accelerator Facility

- RBI double microbeam end station
- Electrostatic beam focusing lens system with ion beam scanner
- Milestone MS26 passed in Dec'23
- ✓ SI fully operational

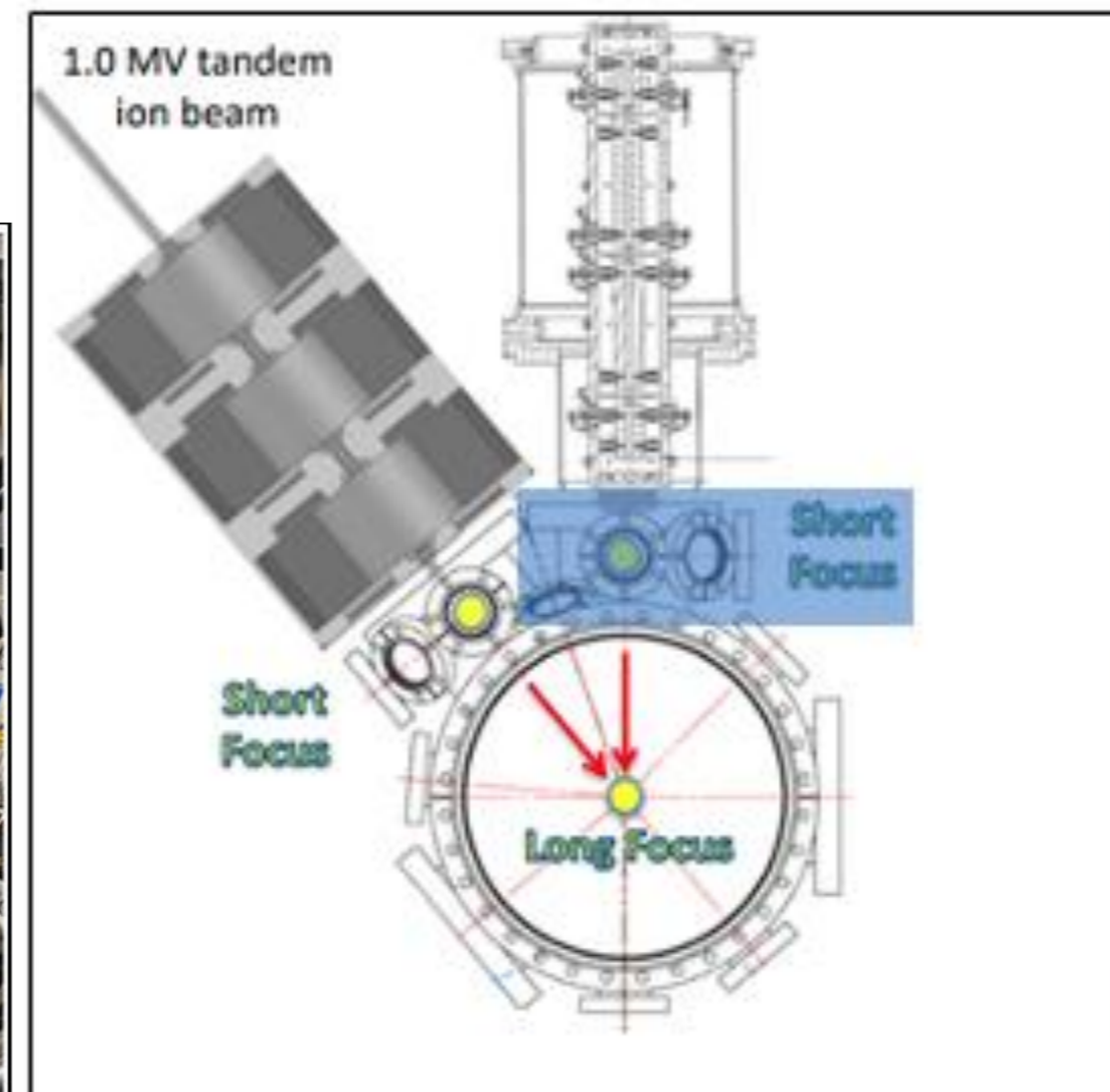
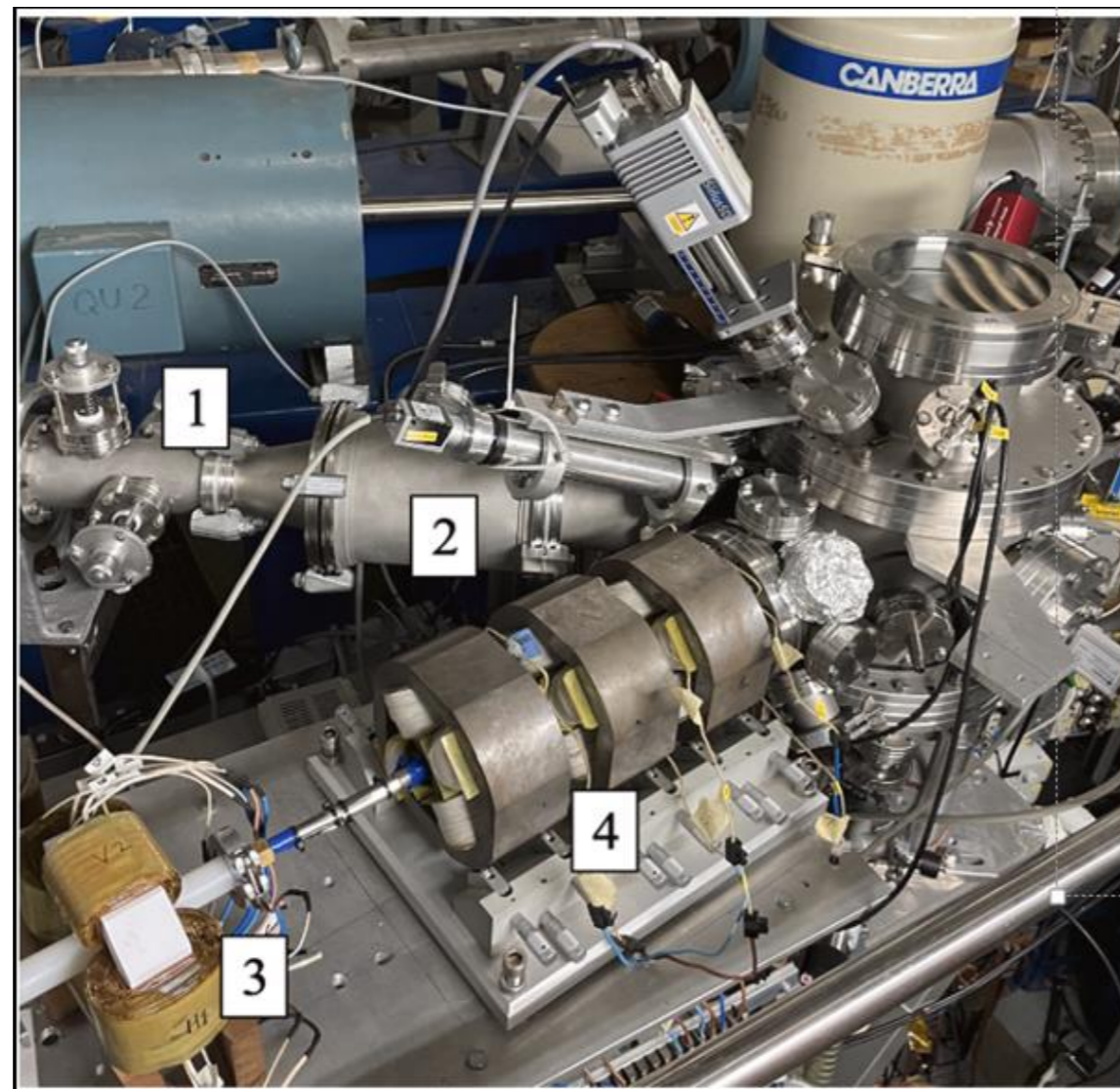
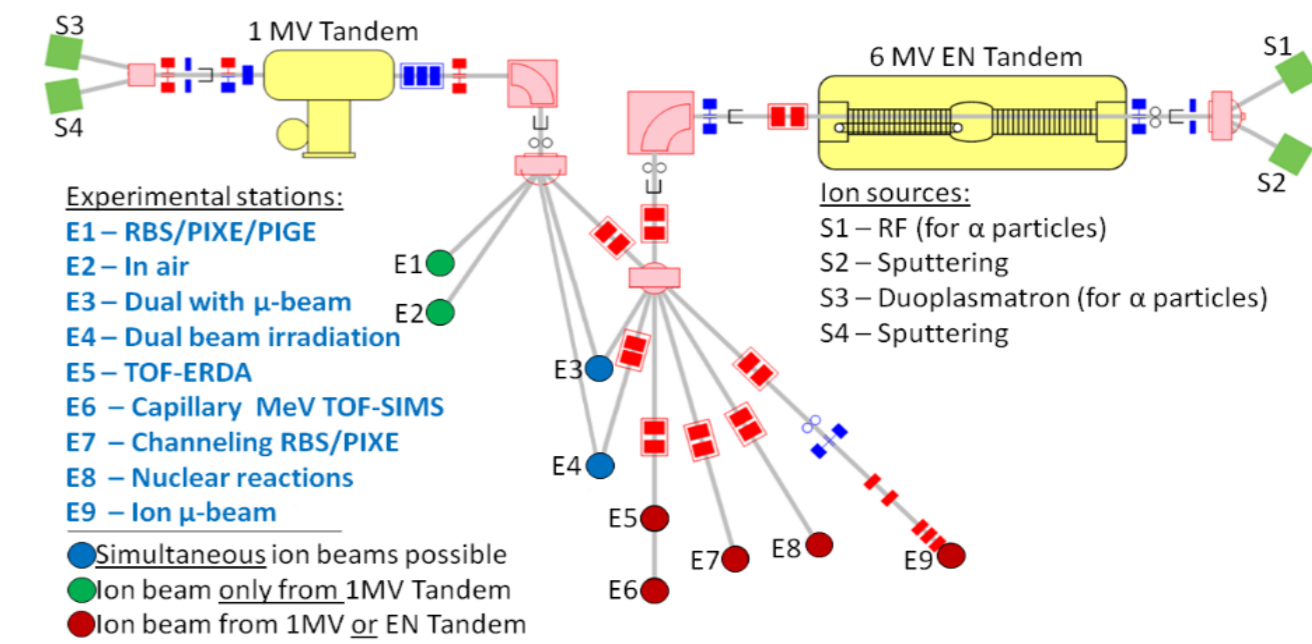

## EMC Test Station

- GUI for ease of operation
- Advanced cooling system to allow tests down to  $-30^{\circ}\text{C}$

- Milestone MS27 passed in Jun'24

✓ SI fully operational

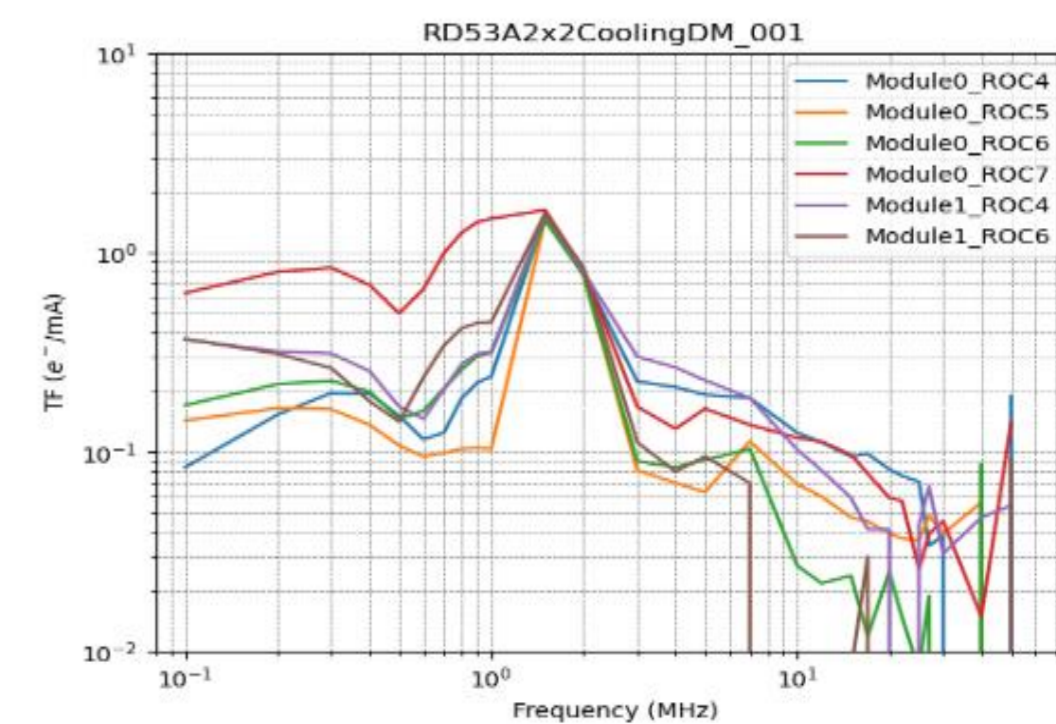
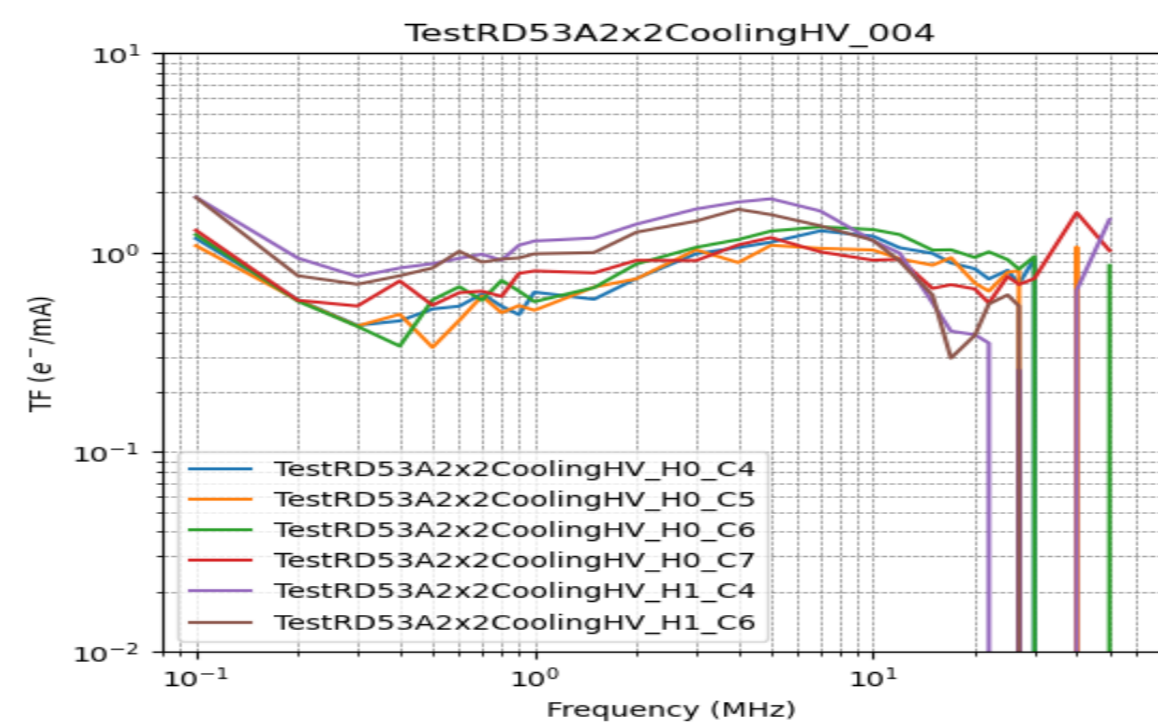
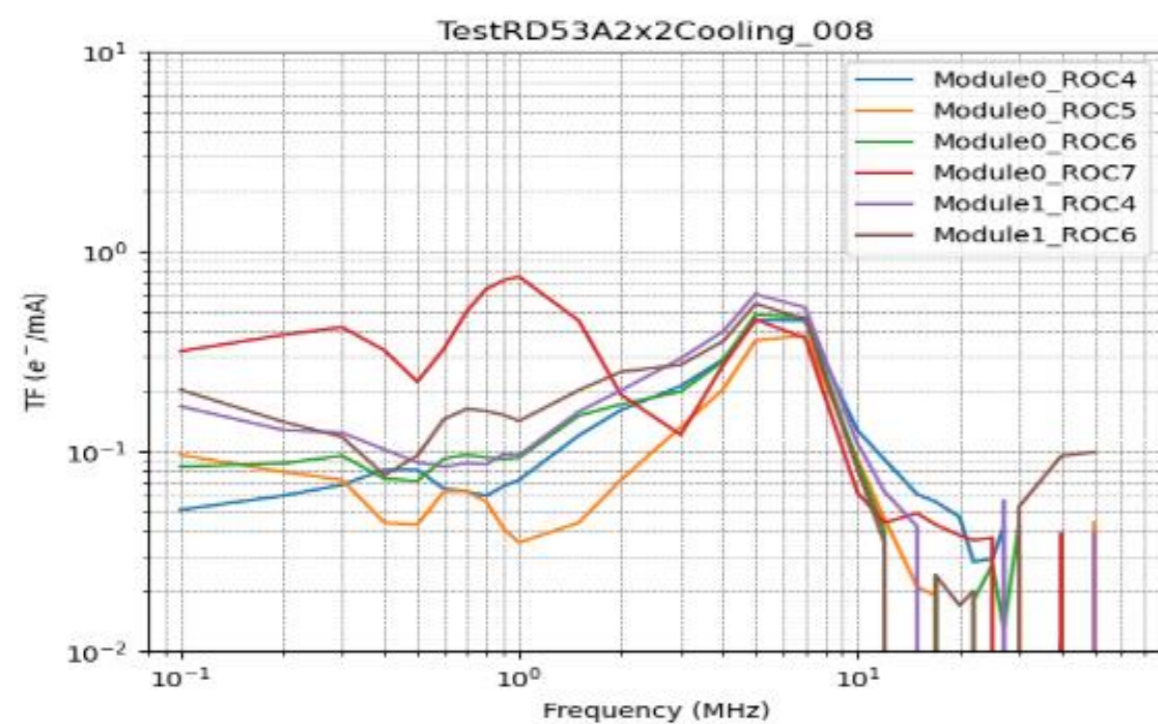

• ITTAINNOVa: WP4.2.1

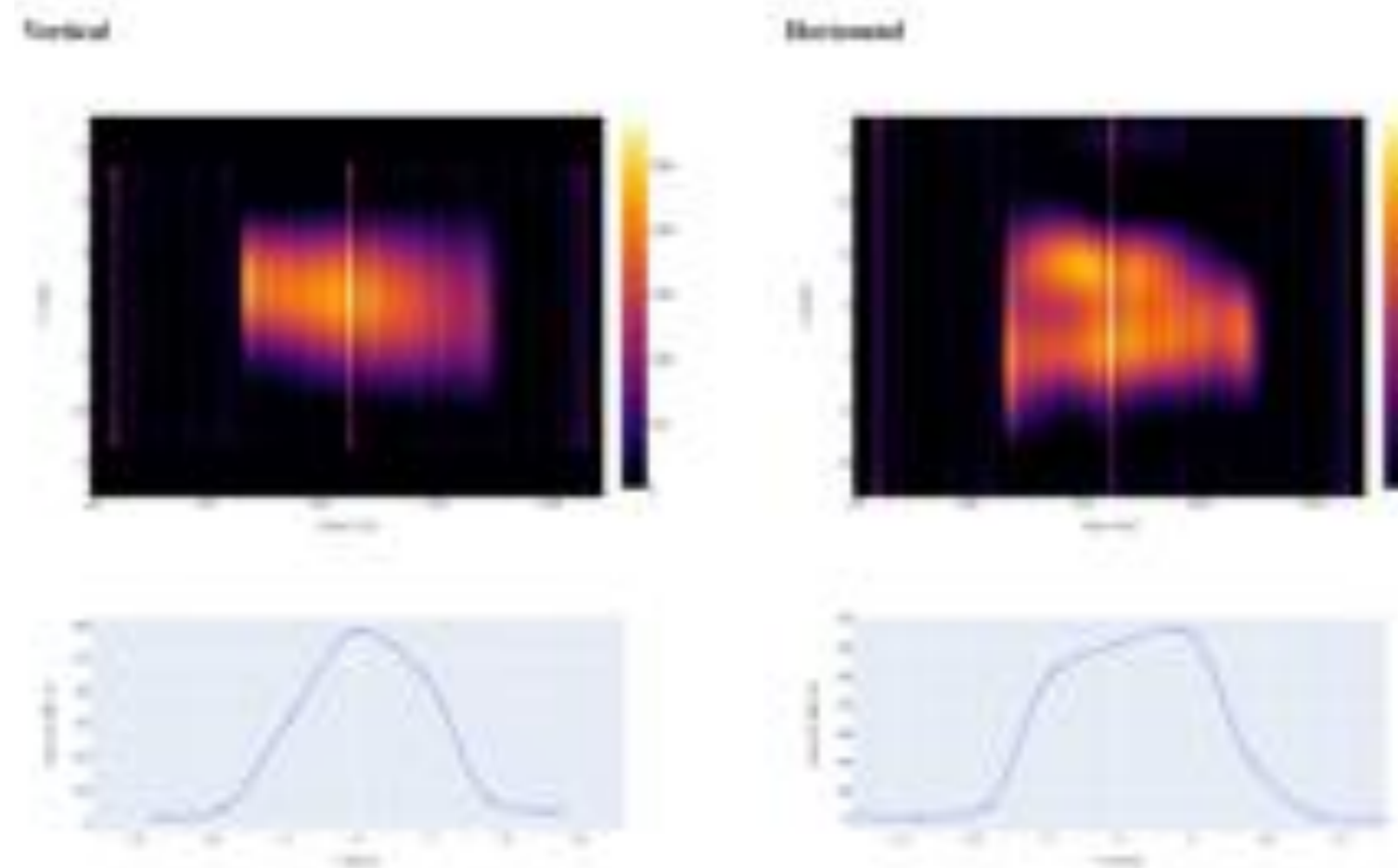

**IRRAD-BPM DAQ electronics (left-hand side)**

**IRRAD beam profile acquired during the run 2025 (right-hand-side)**

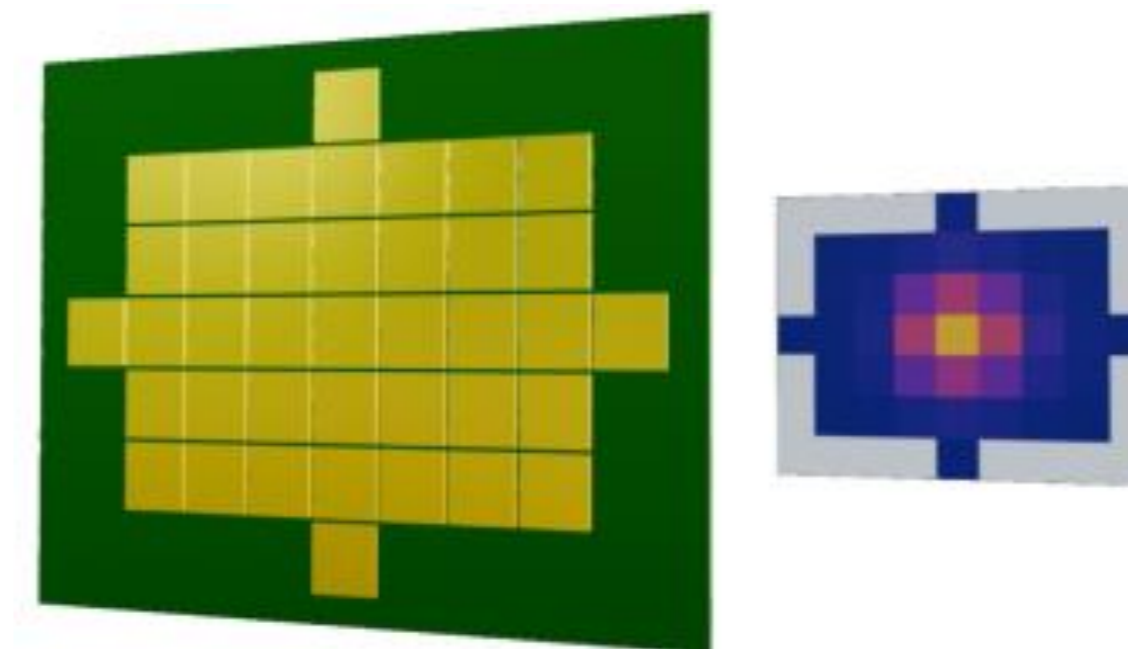
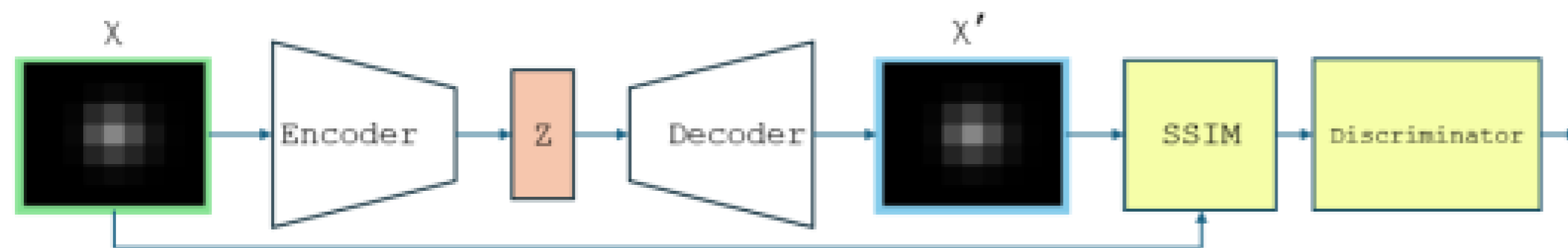

**Graphical model of a BPM-sensor confronted with an example of measurement data seen as an image**

### CAE-architecture for BPM-anomaly detection

- Milestone MS28 (BPM DAQ system) passed in Aug'23
- Milestone MS29 (ML-based beam characterization) passed in Aug'24
- The only SI with 2 milestone reports (instrument, analysis) !

✓ SI fully operational



# 4.4.7: Cd Shielding in the Tangential Channel

## Requirements

- Reduction of thermal neutron flux (sample material activation), low effect on epithermal and fast neutron flux (radiation damage)
- Low impact on normal reactor operation (reactivity, dose rates)

## Monte Carlo calculations

- Flux levels and spectra
- Reactivity effect
- Cd shield activation

## Shield design

- Al open tube, Cd foil on the outside
- Length = 50 cm, interior diameter = 12 cm
- Two shield positions
  - Centered on core (in use)
  - Partially withdrawn (cooling)

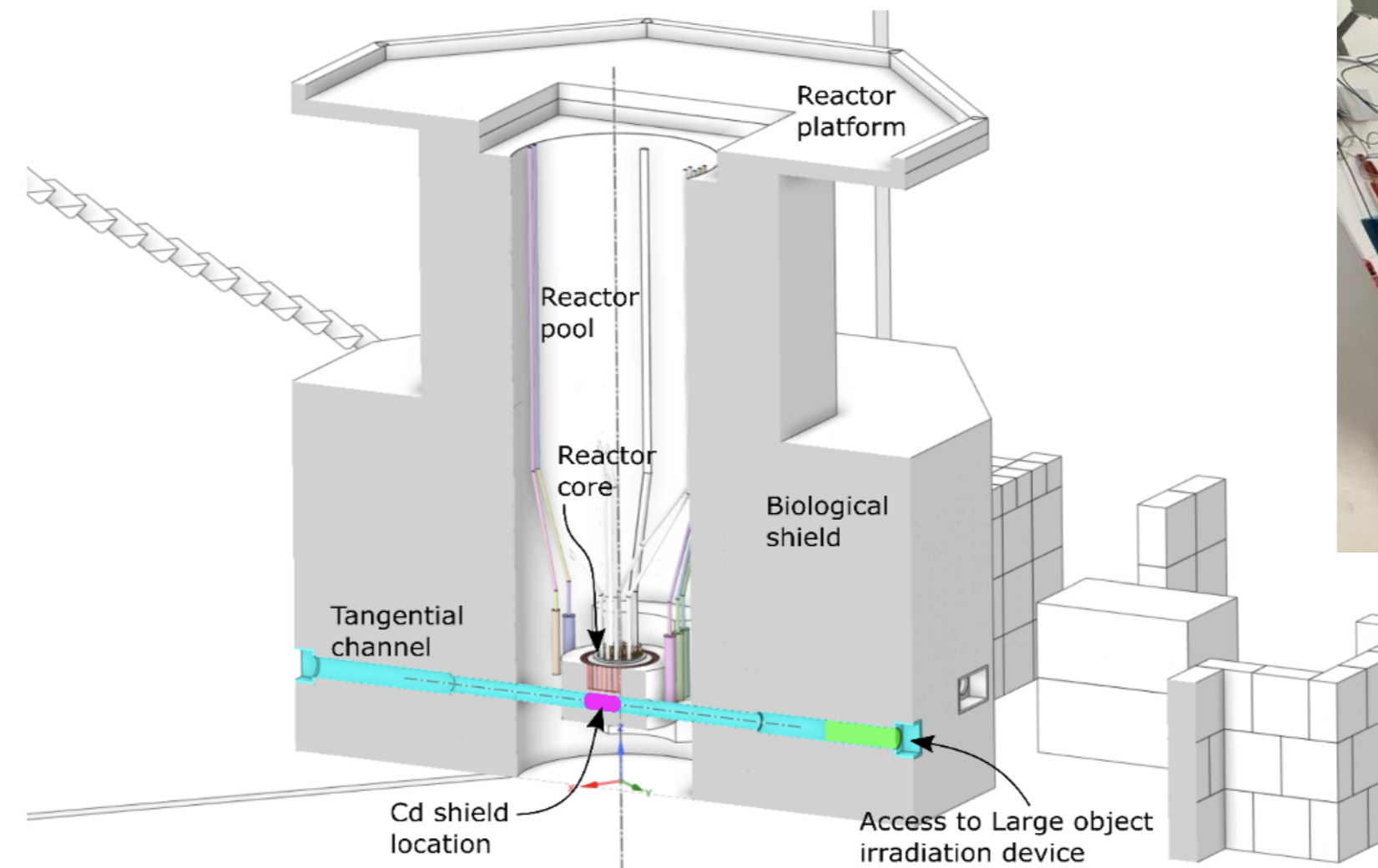

**Actual system out of the channel**

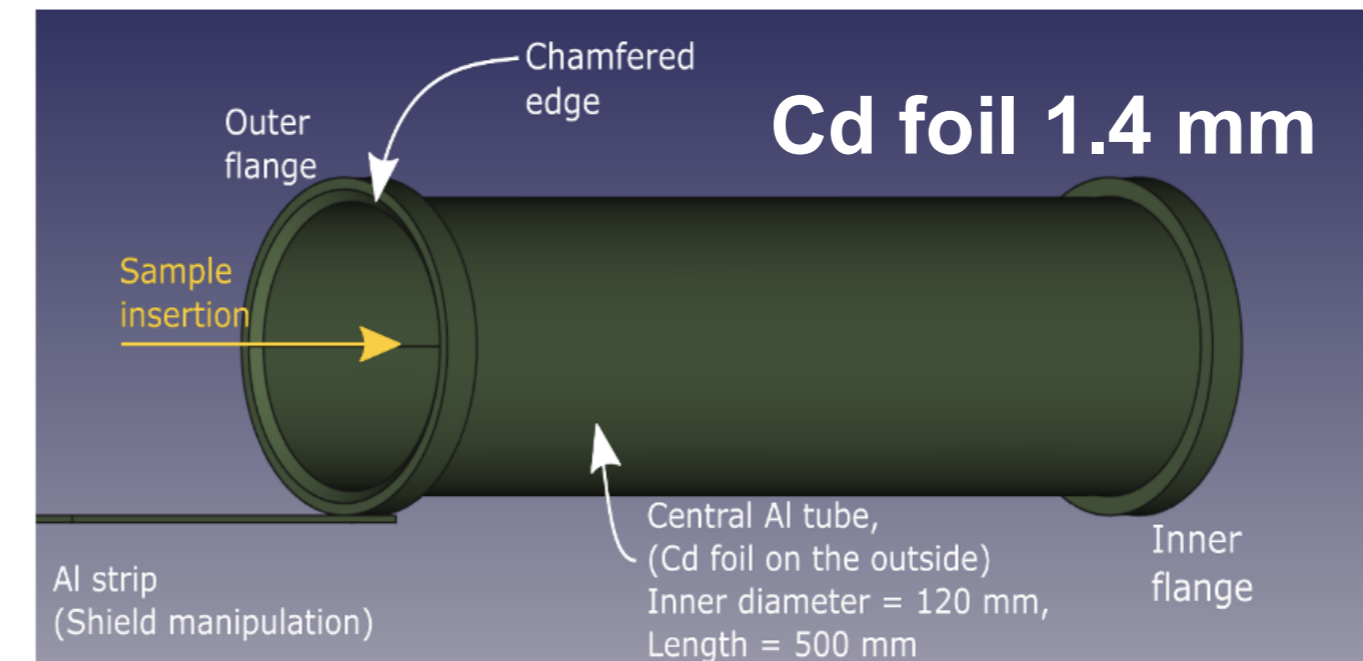
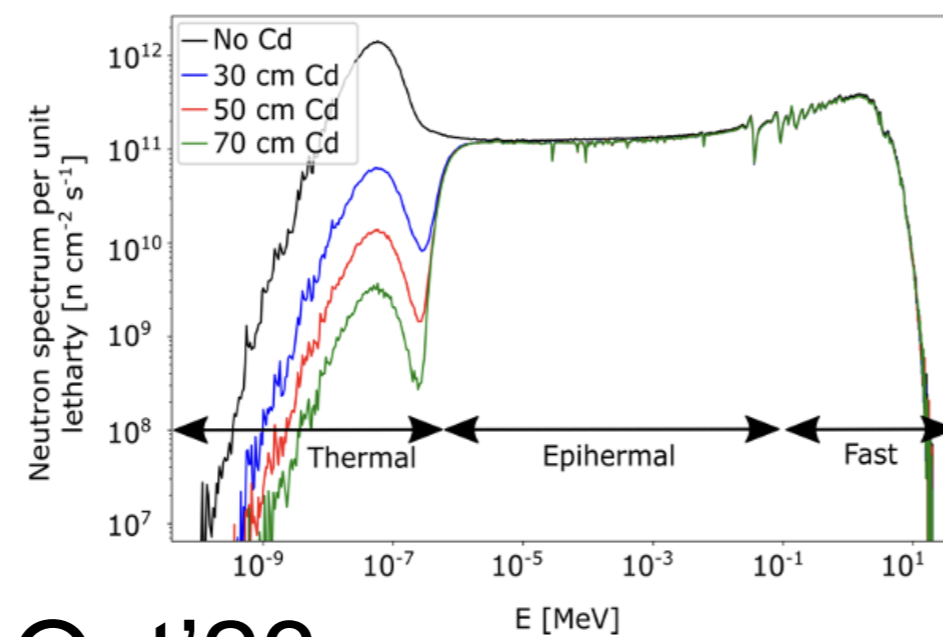

• JSI: WP4.3.3

- Milestone MS30 passed in Oct'23
- Operational aspects (shield activation and subsequent cooling) require careful scheduling of runs without thermal neutrons

✓ SI operational, but no use cases so far

## 4.4.8: Improvements of the irradiation line at AIC-144

AIC-144 cyclotron 60 MeV protons

- Scanner with large coverage of 0.4 m x 0.3 m
- Control software allowing uniform irradiation coverage
- Milestone MS31 passed in Jun'24
- ✓ SI fully operational



**2-D scanner enabling exposure of samples up to 400 mm × 300 mm**

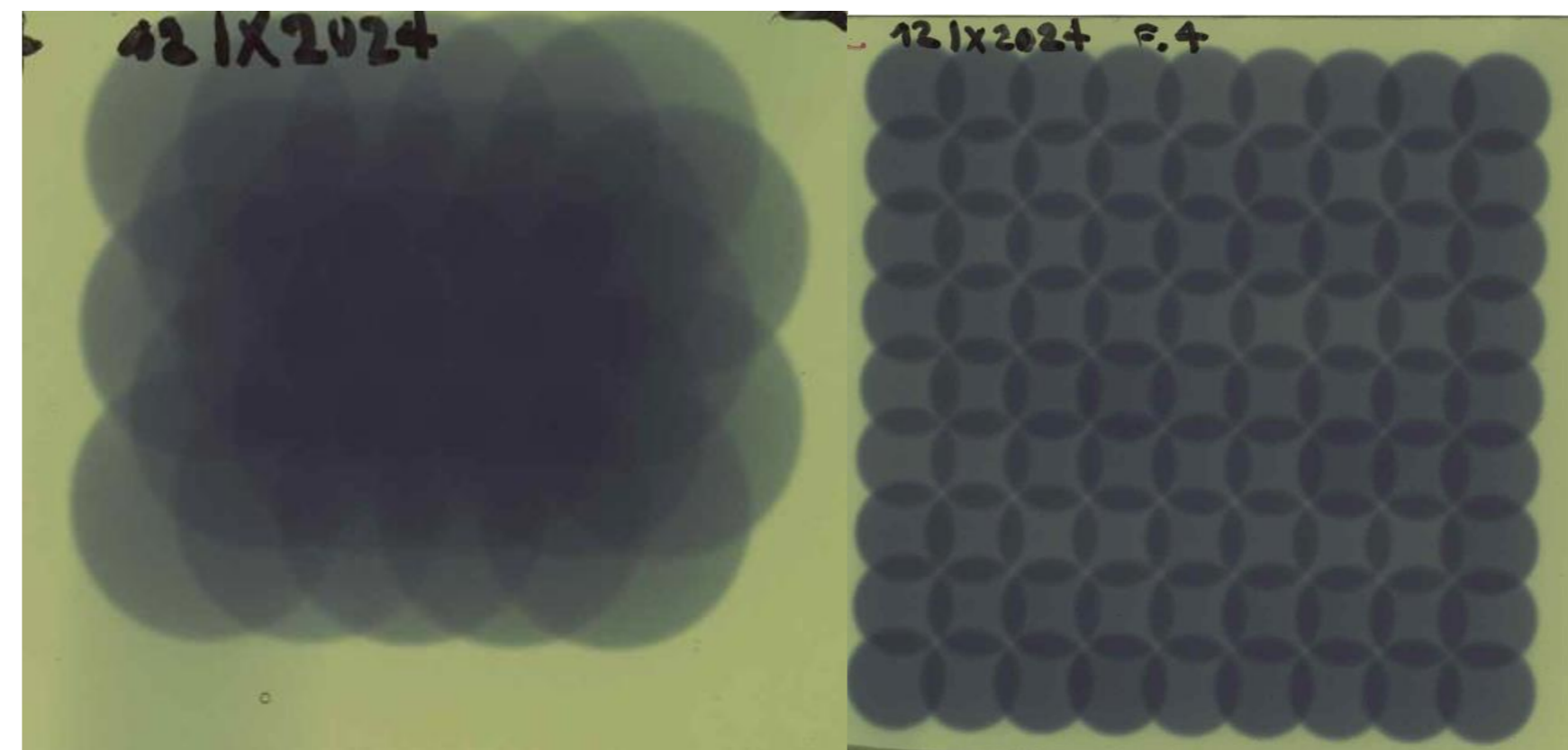

**Gafchromic films irradiated with collimated 60 MeV proton beam using the 2D scanner**



HIF facility at CRC UCLouvain

- Used for SEE tests
- Delivers a cocktail of nine ions at 9.3 MeV/nucleon covering a broad LET range
- Milestone MS32 passed in Aug'23
- Many user benefits from the new design
- Used by 4 out of the 6 funded EURO-LABS projects
- ✓ SI fully operational

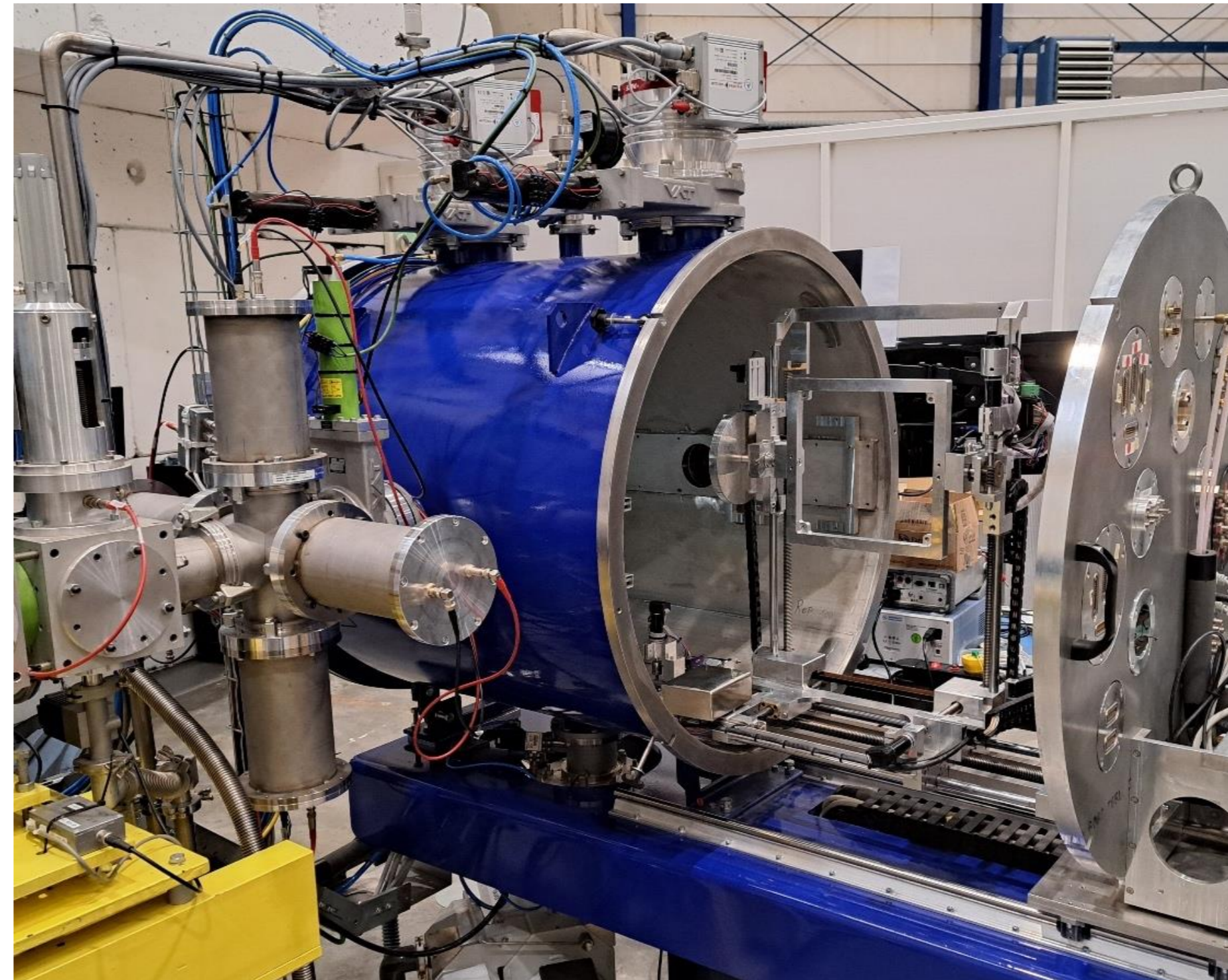

**New HIF line, DUT gets placed in the square frame and the endcap is equipped with several vacuum feedthroughs**



UoB MC40: WP4.3.6

- UoB MC40 cyclotron, 23 MeV p
  - High-speed scanning system to prevent excessive heating
- Milestone MS33 passed in Aug'24
- Allowing an unprecedented combination of sample area and fluence
- Used by 1 + 2 EURO-LABS projects
- ✓ SI fully operational

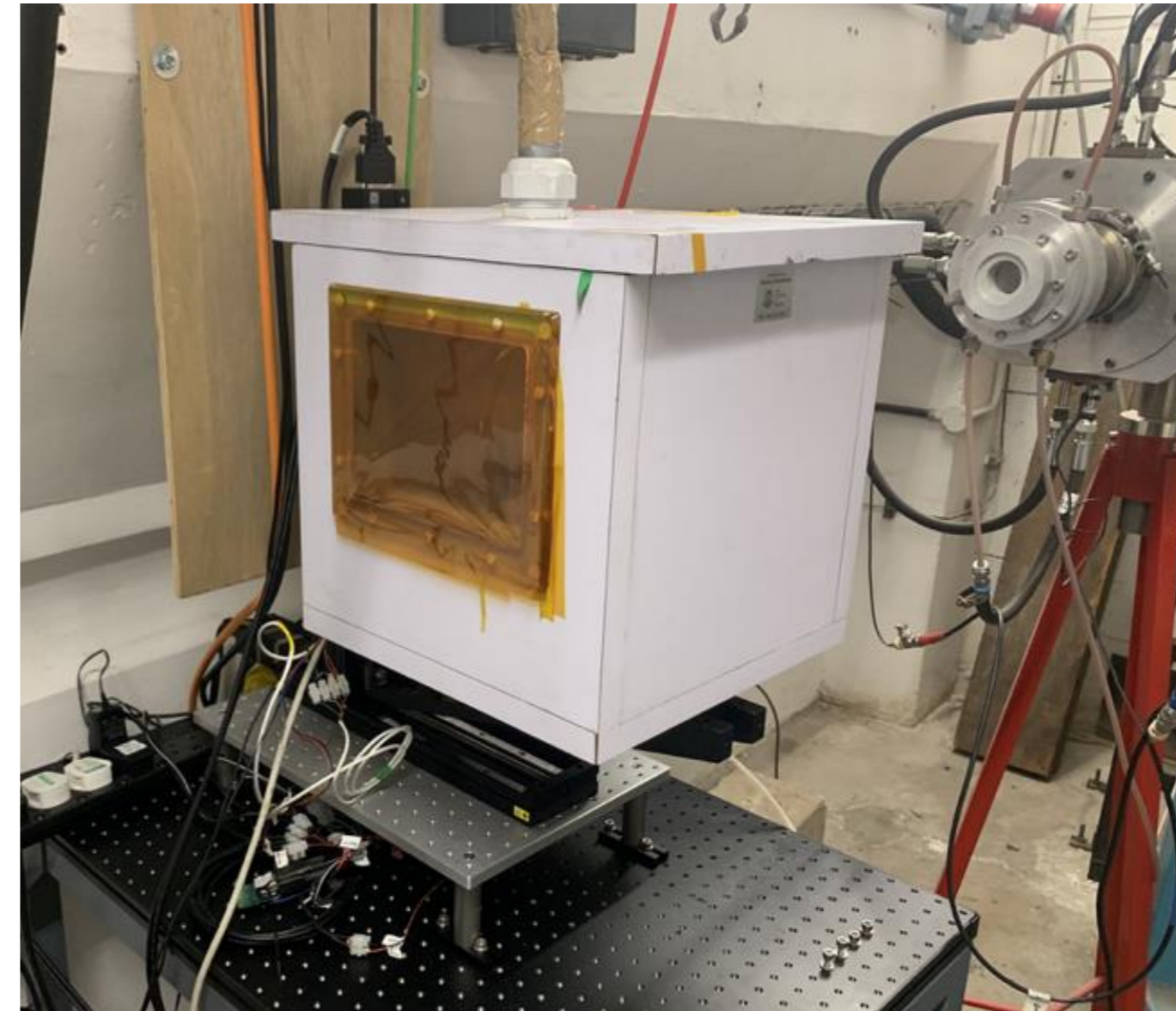

The upgraded sample scanning system installed on the high intensity MC40 beamline

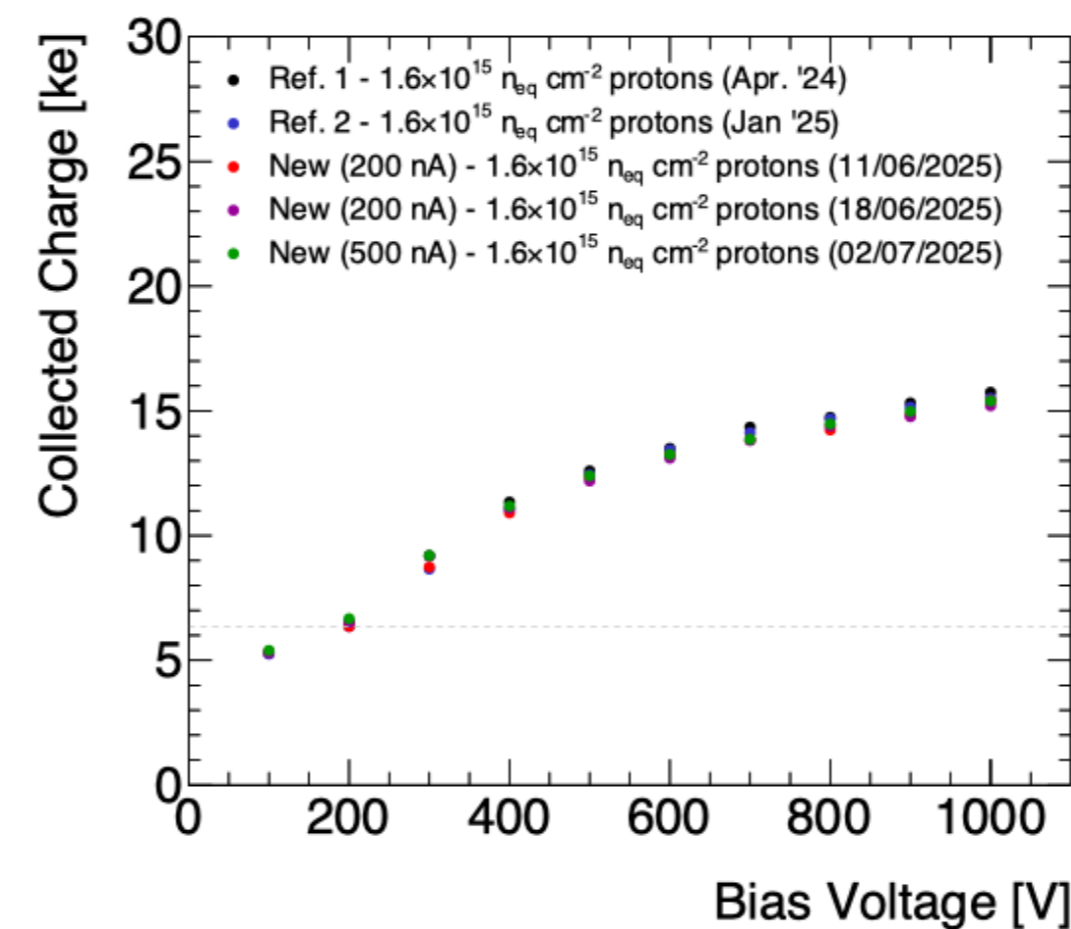

Commissioning of the system with ATLAS ITk strip "mini" sensors



# Task 4.4 Summary

- Service Improvements targeted at improved performance of RIs for EURO-LABS users and beyond
  - All RIs of WP4 except GIF++ (still benefits from improved CERN database)
- Many of the improvements planned before, but EURO-LABS funds enabled kick-starting the projects
  - Remember: RI contribution  $\geq$  EURO-LABS contribution
- Task follow-up: ~1 Milestone per SI, common report to come as Deliverable
- All 10 Milestones achieved in time up to August 2024 (Y2)
- The final traffic-light score:
  - 8 x green (fully operational with use cases in EURO-LABS)
  - 1 x yellow (fully operational, but no use case)
  - 1 x red (project cancelled in the installation phase)
- The SIs of WP4 are a big success !

